



MUSEO DEL NOVECENTO

- 1** IL QUARTO STATO. CRONACA DI UN ACQUISTO
THE FOURTH ESTATE. CHRONICLE OF A PURCHASE
- 2** IL QUARTO STATO | THE FOURTH ESTATE
- 3** FANTASMAGORIA FUTURISTA | FUTURIST
PHANTASMAGORIA
- 4** FUTURISMO | FUTURISM
- 5** VALORI PLASTICI | PLASTIC VALUES
- 6** MEMORIE DEL PASSATO | MEMORIES
OF THE PAST
- 7** ARCAISMI | ARCHAISMS
- 8** L'ARTE TRAGICA E SENZA TEMPO DEGLI ANNI
DEL FASCISMO | THE TRAGIC AND TIMELESS ART
OF THE FASCIST ERA
- 9** GIORGIO MORANDI | GIORGIO MORANDI
- 10** ARIA DI PARIGI | PARIS ATMOSPHERE
- 11** DUE STRADE DELL'ASTRATTISMO | TWO PATHS
FOR ABSTRACT ART
- 12** GEOMETRIE E SENTIMENTO | GEOMETRIES
AND SENSIBILITY
- 13** COLLEZIONE MARINO MARINI | MARINO MARINI
COLLECTION
- 14** LUCIO FONTANA | LUCIO FONTANA
- 15** MILITANZE A CONFRONTO | COMPARING
ACTIVIST MOVEMENTS
- 16** CORRENTE, PICASSISMO, NEOCUBISMO |
CORRENTE, PICASSISM, NEO-CUBISM
- 17** VERSO L'ASSOLUTO | TOWARDS THE ABSOLUTE
- 18** ALBERTO BURRI | ALBERTO BURRI
- 19** NUOVE VIE DELL'ASTRAZIONE | ABSTRACT ART
NEW WAVES
- 20** FESTA CINESE | CHINESE FESTIVAL
- 21** ARTE PROGRAMMATA E CINETICA
PROGRAMMED AND KINETIC ART
- 22** POP, NEW DADA, NUOVO RACCONTO
POP, NEW DADA, NEW NARRATIVE
- 23** POP ART A ROMA | POP ART IN ROME
- 24** CAROL RAMA | CAROL RAMA
- 25** PITTURA, GEOMETRIE, SUPERFICI | PAINTING,
GEOMETRIES, SURFACES
- 26** INSTALLAZIONI. SPECCHI, SGUARDI, SPIRALI
INSTALLATIONS. MIRRORS, LOOKS, SPIRALS
- 27** LUCIANO FABRO | LUCIANO FABRO
- 28** CONCETTUALE, FOTOGRAFIA, GEOGRAFIE
CONCEPTUAL, PHOTOGRAPHY, GEOGRAPHY
- 29** INSTALLAZIONI. SERIE, MATERIE, ARCHETIPI
INSTALLATIONS. SERIES, MATERIALS, ARCHETYPES
- 30** IL RACCONTO DI NUOVO | THE NARRATIVE, AGAIN

- GUARDAROBA | CLOAKROOM
- BIGLIETTERIA | TICKETS
- RISTORANTE E CAFFETERIA | RESTAURANT AND CAFETERIA
- BAGNI | TOILETS
- SCALA MOBILE | ESCALATOR
- ASCENSORE | ELEVATOR

MAPPA 3D | 3D MAP

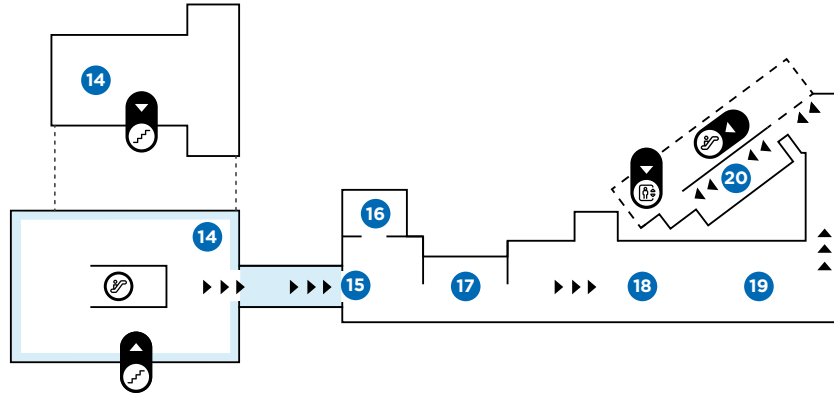
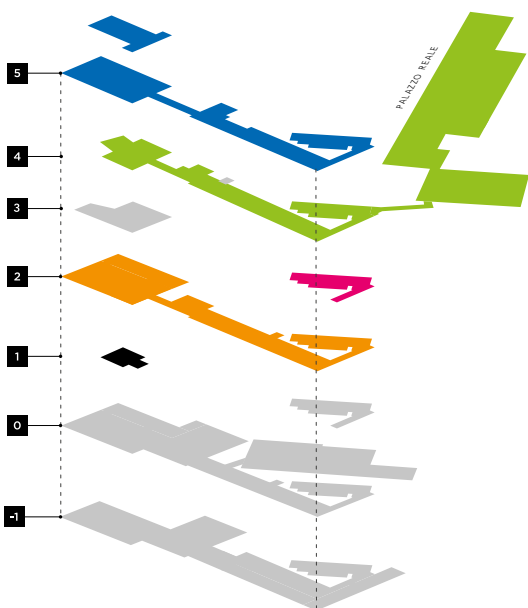

PIANO | FLOOR **5**

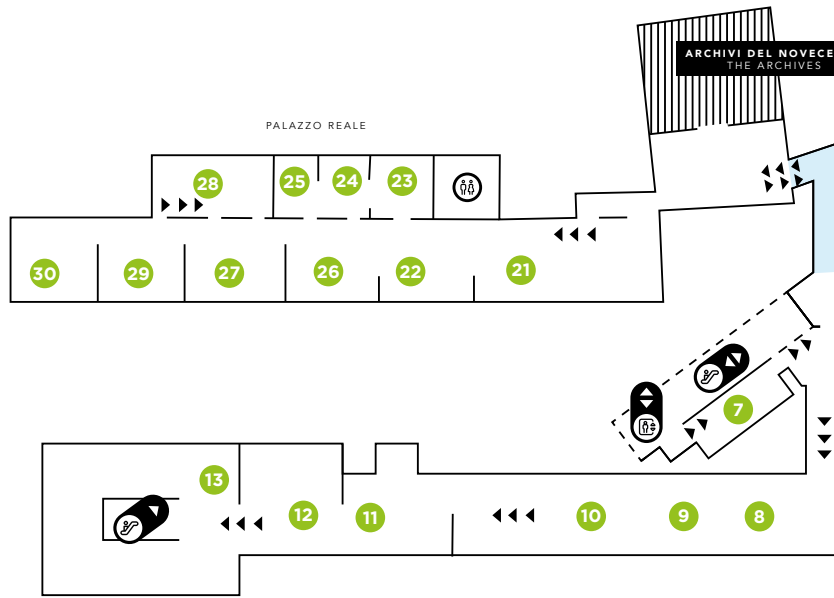

PIANO | FLOOR **4**

**Conclusione del percorso
sale 21-30**
End of exhibition path
21-30 halls

**Continuazione percorso
sale 7-13 e sale 14-20 (piano 3)**
Exhibition path
7-13 halls and 14-20 halls (floor 3)

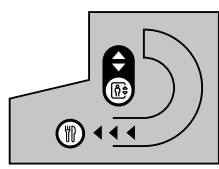

PIANO | FLOOR **3**

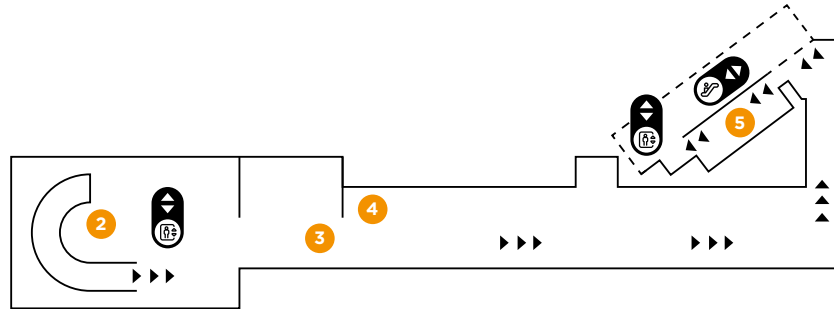

PIANO | FLOOR **2**

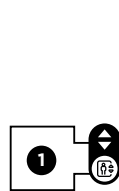

PIANO | FLOOR **1**

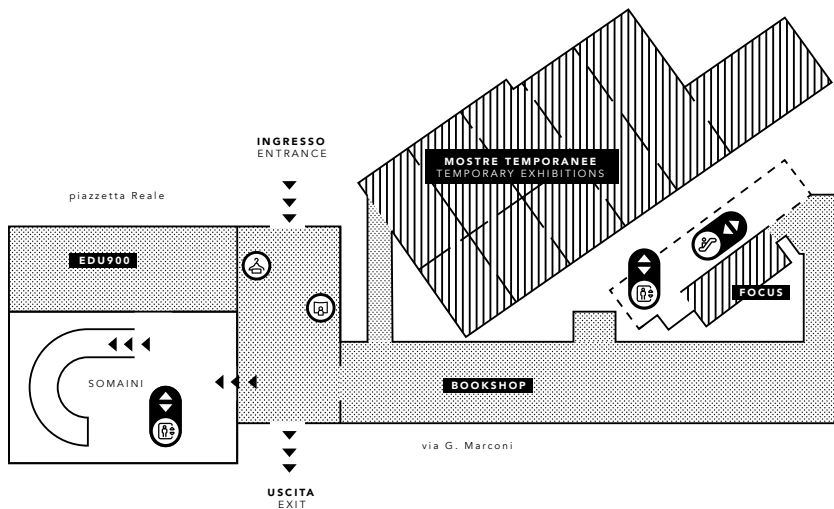
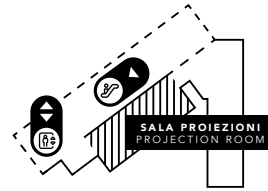

PIANO | FLOOR **0**

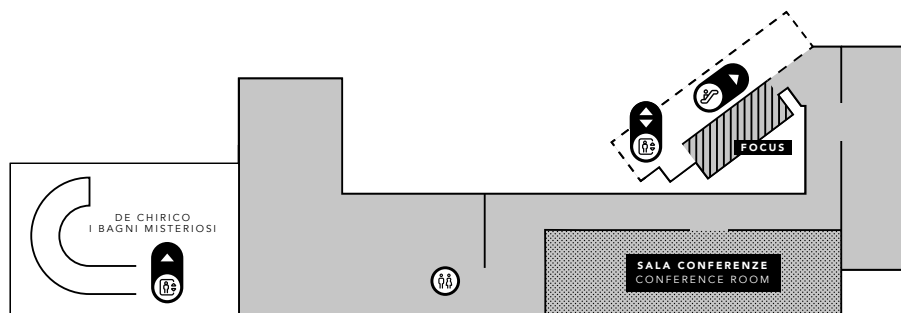

PIANO | FLOOR **-1**